

Installation Note

Configurable Test Set Upgrade Kit

For PNA Series Microwave Network Analyzers (E8362A)

Network Analyzer Model Number	Upgrade Kit Part Number
E8362A	E8362-60101



Agilent Technologies

Agilent Part Number: E8362-90001

Printed in USA June 2002

© Copyright 2002 Agilent Technologies, Inc. All rights reserved.



E8362-90001

Notice

THE MATERIAL CONTAINED IN THIS DOCUMENT IS PROVIDED “AS IS,” AND IS SUBJECT TO BEING CHANGED, WITHOUT NOTICE, IN FUTURE EDITIONS. FURTHER, TO THE MAXIMUM EXTENT PERMITTED BY APPLICABLE LAW, AGILENT DISCLAIMS ALL WARRANTIES, EITHER EXPRESS OR IMPLIED WITH REGARD TO THIS MANUAL AND ANY INFORMATION CONTAINED HEREIN, INCLUDING BUT NOT LIMITED TO THE IMPLIED WARRANTIES OF MERCHANTABILITY AND FITNESS FOR A PARTICULAR PURPOSE. AGILENT SHALL NOT BE LIABLE FOR ERRORS OR FOR INCIDENTAL OR CONSEQUENTIAL DAMAGES IN CONNECTION WITH THE FURNISHING, USE, OR PERFORMANCE OF THIS DOCUMENT OR ANY INFORMATION CONTAINED HEREIN. SHOULD AGILENT AND THE USER HAVE A SEPARATE WRITTEN AGREEMENT WITH WARRANTY TERMS COVERING THE MATERIAL IN THIS DOCUMENT THAT CONFLICT WITH THESE TERMS, THE WARRANTY TERMS IN THE SEPARATE AGREEMENT WILL CONTROL.

Getting Assistance from Agilent

By internet, phone, or fax, get assistance with all your test and measurement needs.

Online assistance: www.agilent.com/find/assist		
United States <i>(tel)</i> 1 800 452 4844	Latin America <i>(tel)</i> (305) 269 7500 <i>(fax)</i> (305) 269 7599	Canada <i>(tel)</i> 1 877 894 4414 <i>(fax)</i> (905) 282-6495
Europe <i>(tel)</i> (+31) 20 547 2323 <i>(fax)</i> (+31) 20 547 2390	Australia <i>(tel)</i> 1 800 629 485 <i>(fax)</i> (+61) 3 9210 5947	New Zealand <i>(tel)</i> 0 800 738 378 <i>(fax)</i> (+64) 4 495 8950
Japan <i>(tel)</i> (+81) 426 56 7832 <i>(fax)</i> (+81) 426 56 7840	Singapore <i>(tel)</i> 1 800 375 8100 <i>(fax)</i> (65) 836 0252	Malaysia <i>(tel)</i> 1 800 828 848 <i>(fax)</i> 1 800 801 664
India <i>(tel)</i> 1 600 11 2929 <i>(fax)</i> 000 800 650 1101	Hong Kong <i>(tel)</i> 800 930 871 <i>(fax)</i> (852) 2506 9233	Taiwan <i>(tel)</i> 0800 047 866 <i>(fax)</i> (886) 2 25456723
Philippines <i>(tel)</i> (632) 8426802 <i>(tel)</i> (PLDT subscriber only) 1 800 16510170 <i>(fax)</i> (632) 8426809 <i>(fax)</i> (PLDT subscriber only) 1 800 16510288	Thailand <i>(tel)</i> (outside Bangkok) (088) 226 008 <i>(tel)</i> (within Bangkok) (662) 661 3999 <i>(fax)</i> (66) 1 661 3714	People's Republic of China <i>(tel)</i> (preferred) 800 810 0189 <i>(tel)</i> (alternate) 10800 650 0021 <i>(fax)</i> 10800 650 0121

About Installing the Upgrade Kit

Products affected	E8362A; all options
Installation to be performed by	Agilent service center or personnel qualified by Agilent
Estimated installation time	2 hours
Estimated verification time	5 minutes

Description of Option 014

An Option 014 analyzer can be configured to measure high-power devices and devices that require high dynamic range.

For a high-power measurement, external amplifiers and high power attenuators or isolators can be added to complete the test setup. In this configuration, test-port output-power up to 1 Watt (+30 dBm) can be applied to the device under test (DUT). Additionally, there is an external reference input that allows the external amplifier's frequency response and drift to be ratioed out.

For high dynamic range measurements, front panel jumpers are configured to reverse the signal path through one of the couplers. This allows for a 15 dB improvement in transmitted signal sensitivity in one direction only. These jumpers can also be configured on both ports, allowing the user to perform high dynamic range measurements in both the forward and reverse directions.

Items Included in the Upgrade Kit

Table 1 lists the parts included in this upgrade kit, Agilent part number E8362-60101. Check the contents of your kit against this list. If any item is missing or damaged, contact Agilent Technologies. Refer to [“Getting Assistance from Agilent” on page 2](#).

Table 1 Contents of Option 014 Upgrade Kit (E8362-60101)

Ref Desig.	Description	Qty	Part Number
The following parts are required for ALL analyzers			
	Installation note (this document)	1	E8362-90001
	Cable clamp	1	1400-1439
W60	Front-panel jumper	6	08720-20098
W65	RF cable, ch R1 attenuator to REFERENCE 1 SOURCE OUT	1	E8362-20007
W66	RF cable, ch R2 attenuator to REFERENCE 2 SOURCE OUT	1	E8362-20008
W67	RF cable, A25 test port 1 coupler to PORT 1 CPLR ARM	1	E8362-20020
W68	RF cable, A26 test port 2 coupler to PORT 2 CPLR ARM	1	E8362-20021
W69	RF cable, PORT 1 RCVR A IN to A27 ch A mixer	1	E8362-20022
W72	RF cable, PORT 2 RCVR B IN to A30 ch B mixer	1	E8362-20023
The following parts are required only for analyzers WITHOUT Option UNL installed			
	Lower front panel overlay (Option 014)	1	E8364-80003
W61	RF cable, A22 switch splitter to PORT 1 SOURCE OUT	1	E8362-20016
W62	RF cable, A22 switch splitter to PORT 2 SOURCE OUT	1	E8362-20017
W63	RF cable, PORT 1 CPLR THRU to A25 test port 1 coupler	1	E8362-20018
W64	RF cable, PORT 2 CPLR THRU to A26 test port 2 coupler	1	E8362-20019
W70	RF cable, REFERENCE 1 RCVR R1 IN to A28 ch R1 mixer	1	E8362-20029
W71	RF cable, REFERENCE 2 RCVR R2 IN to A29 ch R2 mixer	1	E8362-20030
The following parts are required only for analyzers WITH Option UNL installed			
	Lower front panel overlay (Option UNL/014)	1	E8364-80011
W70	RF cable, REFERENCE 1 RCVR R1 IN to A28 ch R1 mixer	1	E8362-20014
W71	RF cable, REFERENCE 2 RCVR R2 IN to A29 ch R2 mixer	1	E8362-20015
W81	RF cable, A36 step attenuator to PORT 1 SOURCE OUT	1	E8362-20024
W82	RF cable, A37 step attenuator to PORT 2 SOURCE OUT	1	E8362-20025
W83	RF cable, PORT 1 CPLR THRU to A38 bias tee	1	E8362-20012
W84	RF cable, PORT 2 CPLR THRU to A39 bias tee	1	E8364-20013

Installation Procedure for the Upgrade Kit

The network analyzer must be in proper working condition prior to installing this option. Any necessary repairs must be made before proceeding with this installation.

WARNING **This installation requires the removal of the analyzer's protective outer covers. The analyzer must be powered down and disconnected from the mains supply before performing this procedure.**

Electrostatic Discharge Protection

Protection against electrostatic discharge (ESD) is essential while removing or connecting cables or assemblies within the network analyzer.

Static electricity can build up on your body and can easily damage sensitive internal circuit elements when discharged. Static discharges too small to be felt can cause permanent damage. To prevent damage to the instrument:

- *always* wear a grounded wrist strap having a 1 M Ω resistor in series with it when handling components and assemblies.
- *always* use a grounded, conductive table mat while working on the instrument.
- *always* wear a heel strap when working in an area with a conductive floor. If you are uncertain about the conductivity of your floor, wear a heel strap.

Figure 1 shows a typical ESD protection setup using a grounded mat and wrist strap. Refer to “Tools and Equipment Required for the Installation” on page 6 for part numbers.

Figure 1 ESD Protection Setup

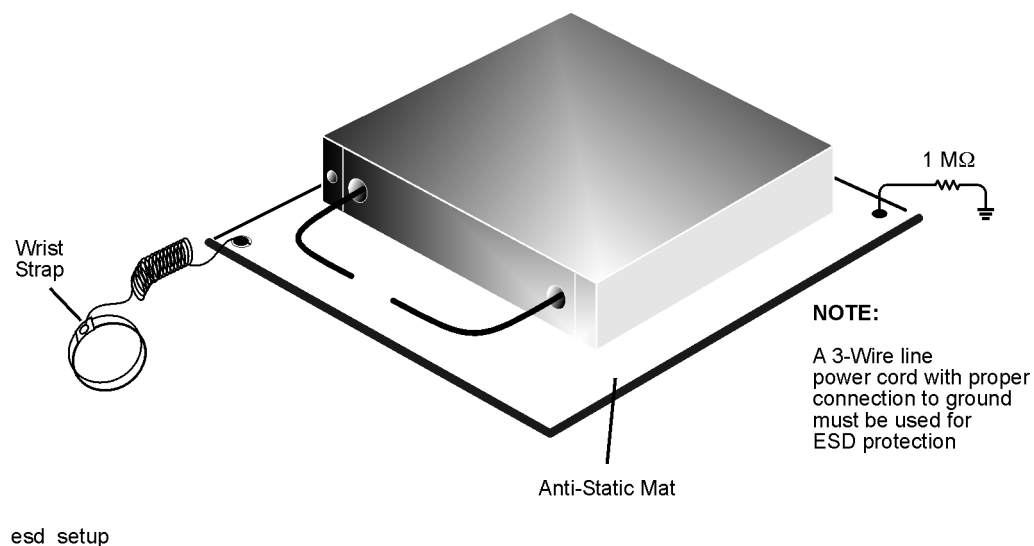

Overview of the Installation Procedure

The following steps comprise the installation of the Option 014 upgrade kit.

1. Remove the outer cover.
2. Remove the front panel assembly.
3. Raise the receiver deck.
4. Remove the existing cables.
5. Install the Option 014 cables.
6. Lower and fasten the receiver deck.
7. Replace the lower front panel overlay.
8. Reinstall the front panel assembly and install the front panel jumpers.
9. Reinstall the outer cover.
10. Enable Option 014.
11. Verify that Option 014 is enabled.

Tools and Equipment Required for the Installation

Description	Qty	Part Number
T-10 TORX driver (set to 9 in-lbs)	1	N/A
T-20 TORX driver (set to 21 in-lbs)	1	N/A
5/16 in torque wrench (set to 10 in-lbs)	1	N/A
5/16 in torque wrench (set to 21 in-lbs)	1	N/A
ESD grounding wrist strap	1	9300-1367
5 ft grounding cord for wrist strap	1	9300-0980
2 x 4 ft conductive table mat and 15 ft grounding wire	1	9300-0797
ESD heel strap (for use with conductive floors)	1	9300-1308

CAUTION Use a 5/16-in torque wrench set to 10 in-lbs on all cable connections except the front-panel adapters to which the front-panel jumpers attach. Use a 5/16-in torque wrench set to 21 in-lbs for these connections.

Step 1. Remove the Outer Cover

CAUTION This procedure is best performed with the analyzer resting on its front handles in the vertical position. *Do not place the analyzer on its front panel without the handles.* This will damage the front panel assemblies.

Refer to [Figure 2](#) for this procedure.

1. Disconnect the power cord (if it has not already been disconnected).
2. With a T-20 TORX driver, remove the strap handles (item ①) by loosening the screws (item ②) on both ends until the handle is free of the analyzer.
3. With a T-20 TORX driver, remove the four rear panel feet (item ③) by removing the center screws (item ④).
4. Slide the four bottom feet (item ⑤) off the cover.
5. Slide the cover off of the frame.

Figure 2 Outer Cover Removal

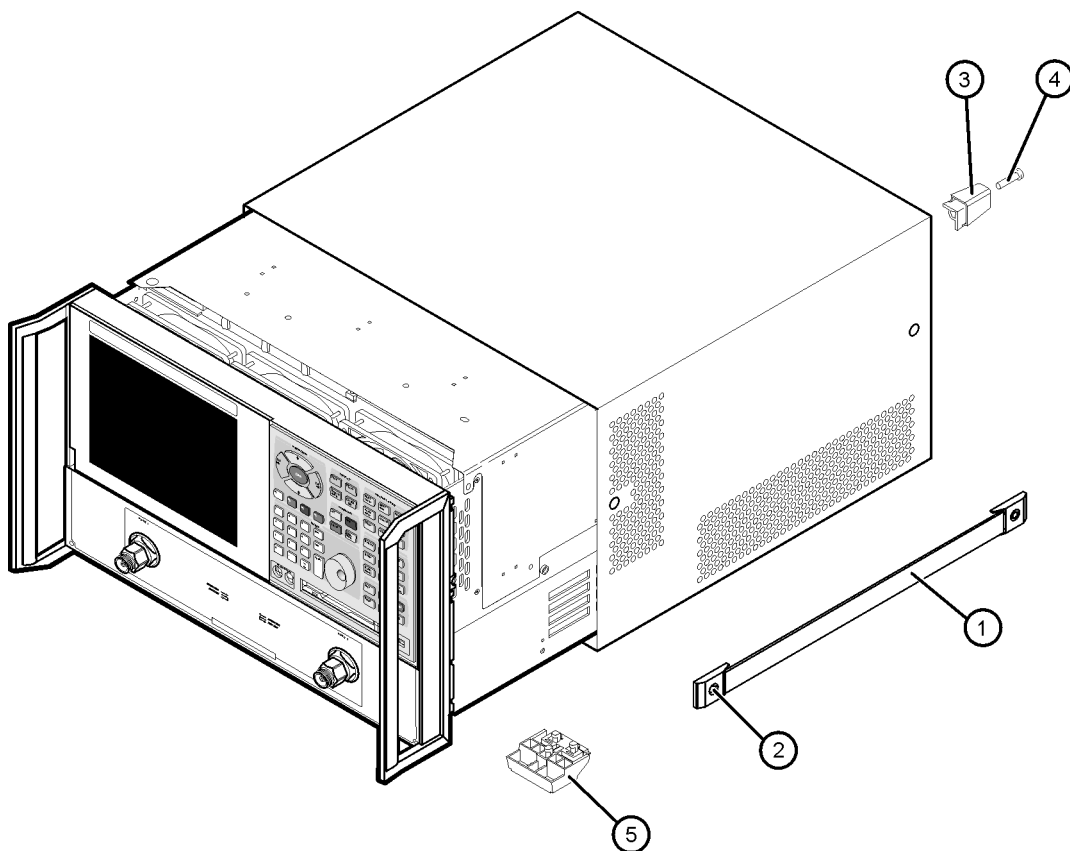

dt501a

Step 2. Remove the Front Panel Assembly

Refer to [Figure 3](#) for this procedure.

1. With a T-10 TORX driver, remove the eight screws (item ①) from the sides of the frame.

CAUTION Before removing the front panel from the analyzer, lift and support the front of the analyzer chassis.

2. Slide the front panel over the test port connectors.
3. Disconnect the front panel interface ribbon cable (item ②). The front panel is now free from the analyzer.

Figure 3 Front Panel Assembly Removal

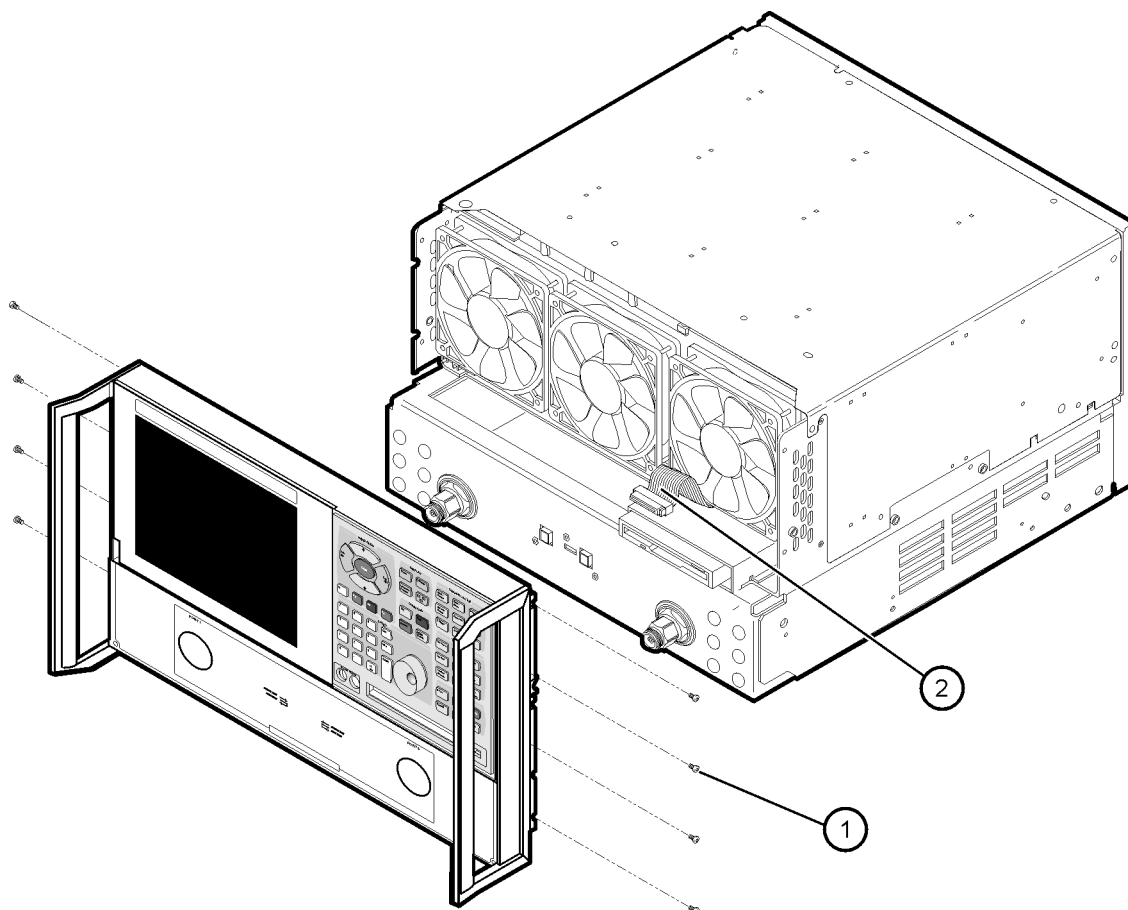

dt513a

Step 3. Raise the Receiver Deck

Refer to [Figure 4](#) for this procedure.

1. Place the analyzer bottom-side up on a flat surface.
2. With a T-10 TORX driver, remove the four screws, (item ①), that secure the receiver deck.
3. Pull the latch pin (item ②) towards the center of the analyzer to release the receiver deck. Be sure to pull only item ②. The other two latch pins are the pivot pins for the receiver deck. Pulling them will result in complete removal of the deck from the analyzer.
4. Lift the receiver deck to partially raise it, then release the latch pin (item ②). Lift the receiver deck to its fully raised position and ensure that the latch pin latches in the raised position.

Figure 4 Receiver Deck, Raising

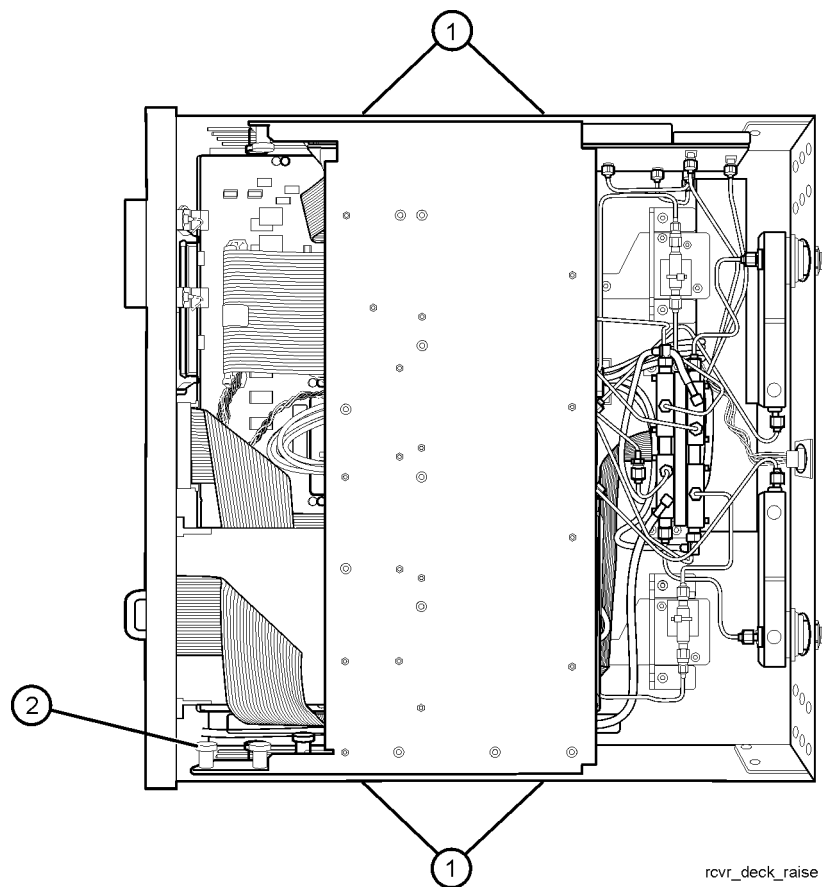

Step 4. Remove the Existing Cables

Analyzers without Option UNL

Refer to [Figure 5](#) for the following procedure.

If you are installing Option 014 on an analyzer that does not have Option UNL installed, remove the following cables in the order listed:

- W7 E8362-20005 Channel R1 attenuator to A28 channel R1 mixer
- W8 E8362-20006 Channel R2 attenuator to A29 channel R2 mixer
- W9 E8364-20019 A25 test port 1 coupler to A27 channel A mixer
- W10 E8364-20020 A26 test port 2 coupler to A30 channel B mixer
- W5 E8364-20021 A22 switch splitter to A25 test port 1 coupler
- W6 E8364-20022 A22 switch splitter to A26 test port 2 coupler

Figure 5 Cable Removal, Analyzers without Option UNL

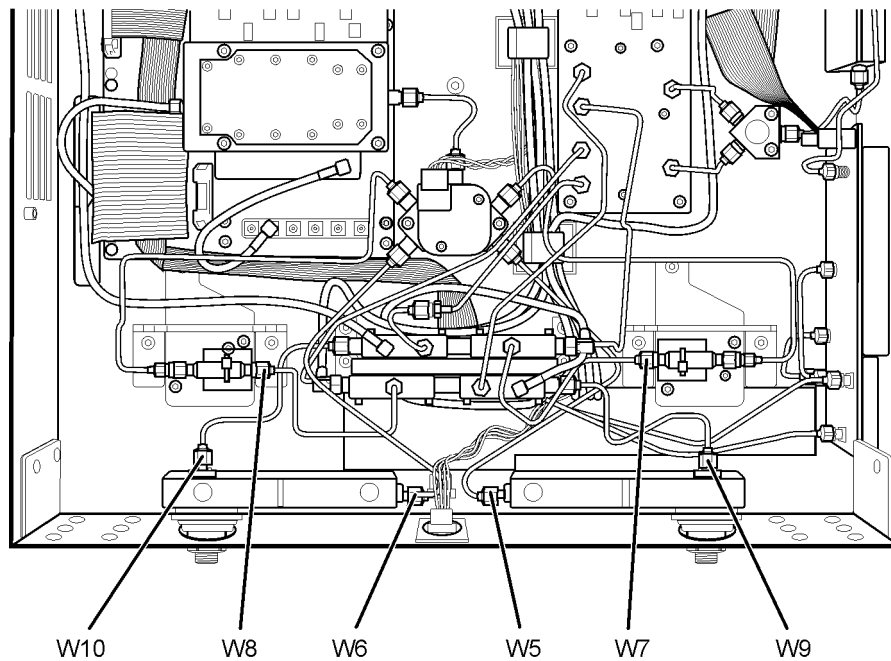

cbi_rmv_std

Analyzers with Option UNL

Refer to [Figure 6](#) for the following procedure.

If you are installing Option 014 on an analyzer that has Option UNL installed, remove the following cables in the order listed:

- W8 E8362-20028 Channel R2 attenuator to A29 channel R2 mixer
- W7 E8362-20027 Channel R1 attenuator to A28 channel R1 mixer
- W53 E8362-20009 A36 step attenuator to A38 bias tee
- W54 E8362-20009 A37 step attenuator to A39 bias tee
- W10 E8364-20020 A26 test port 2 coupler to A30 channel B mixer
- W9 E8364-20019 A25 test port 1 coupler to A27 channel A mixer

Figure 6 Cable Removal, Analyzers with Option UNL

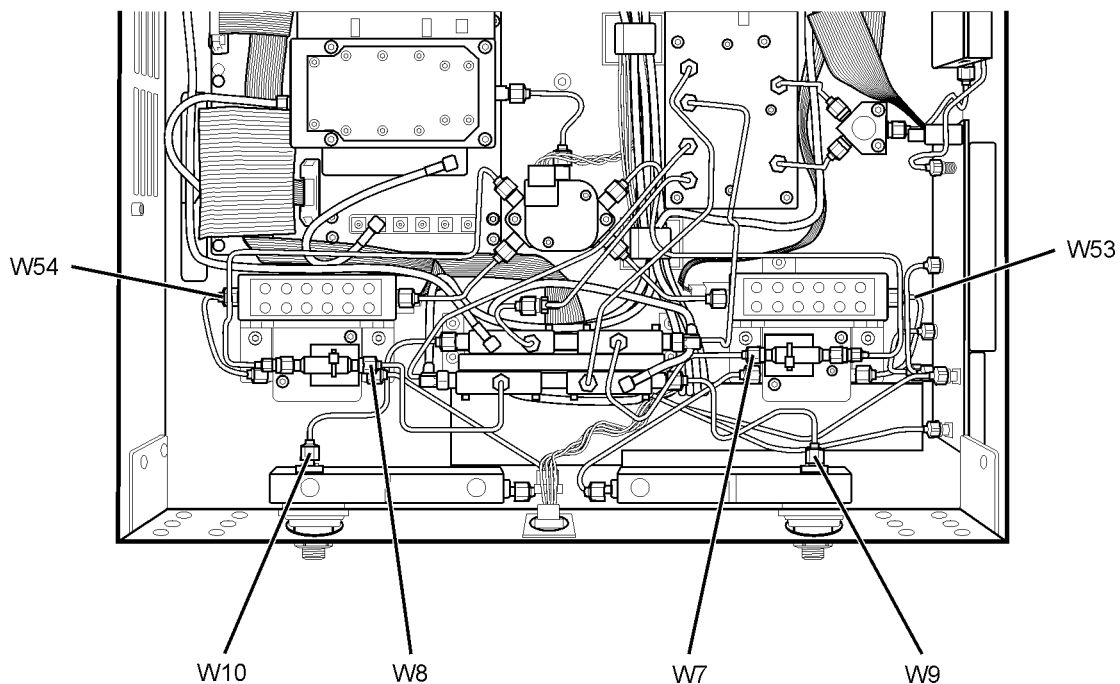

cbl_rmv_unl

Step 5. Install the Option 014 Cables

Analyzers without Option UNL

Refer to [Figure 7](#) for the following procedure. The new parts referenced in this procedure are listed in [Table 1 on page 4](#).

If you are installing Option 014 on an analyzer that does not have Option UNL installed, install the following cables in the order listed. Use a 5/16-in torque wrench set to 10 in-lbs.

- W70 E8362-20029 REFERENCE 1 RCVR R1 IN to A28 channel R1 mixer
- W71 E8362-20030 REFERENCE 2 RCVR R2 IN to A29 channel R2 mixer
- W68 E8362-20021 A26 test port 2 coupler to PORT 2 CPLR ARM
- W72 E8362-20023 PORT 2 RCVR B IN to A30 channel B mixer
- W62 E8362-20017 A22 switch splitter to PORT 2 SOURCE OUT
- W64 E8362-20019 PORT 2 CPLR THRU to A26 test port 2 coupler
- W66 E8362-20008 Channel R2 attenuator to REFERENCE 2 SOURCE OUT
- W67 E8362-20020 A25 test port 1 coupler to PORT 1 CPLR ARM
- W69 E8362-20022 PORT 1 RCVR A IN to A27 channel A mixer
- W61 E8362-20016 A22 switch splitter to PORT 1 SOURCE OUT
- W63 E8362-20018 PORT 1 CPLR THRU to A25 test port 1 coupler
- W65 E8362-20007 Channel R1 attenuator to REFERENCE 1 SOURCE OUT

Figure 7 Option 014 Cable Installation, Analyzers without Option UNL

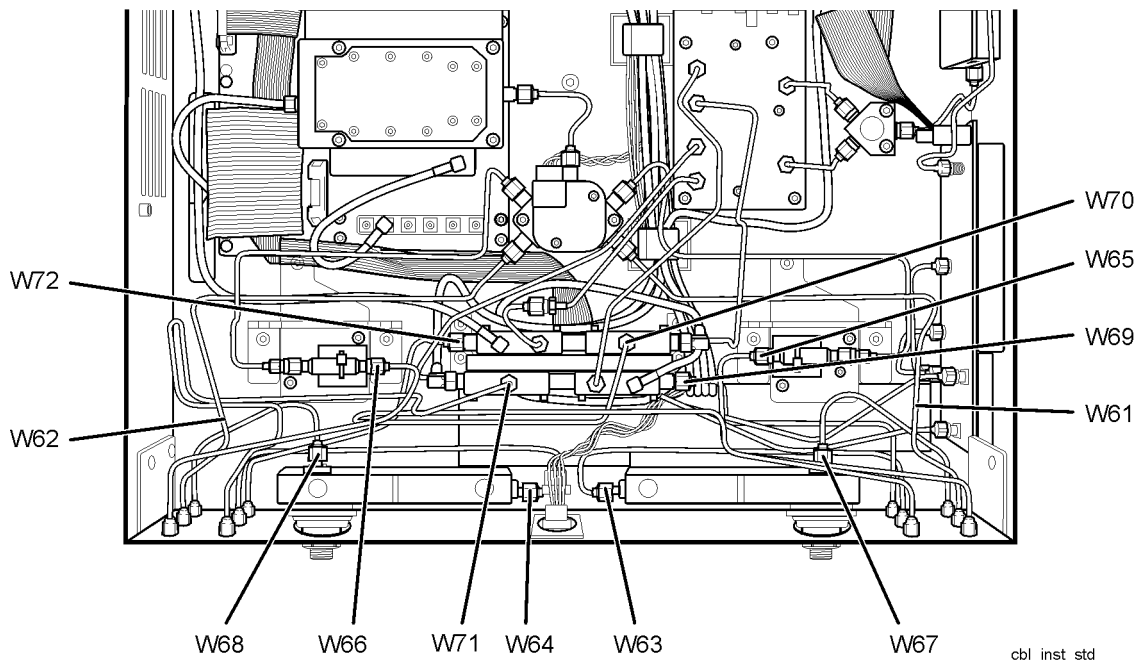

Analyzers with Option UNL

Refer to [Figure 8](#) for the following procedure. The new parts referenced in this procedure are listed in [Table 1 on page 4](#).

If you are installing Option 014 on an analyzer that has Option UNL installed, install the following cables in the order listed. Use a 5/16-in torque wrench set to 10 in-lbs.

- W71 E8362-20015 REFERENCE 2 RCVR R2 IN to A29 channel R2 mixer
- W70 E8362-20014 REFERENCE 1 RCVR R1 IN to A28 channel R1 mixer
- W68 E8362-20021 A26 test port 1 coupler to PORT 2 CPLR ARM
- W72 E8362-20023 PORT 2 RCVR B IN to A30 channel B mixer
- W82 E8362-20025 A37 step attenuator to PORT 2 SOURCE OUT
- W84 E8362-20013 PORT 2 CPLR THRU to A39 bias tee
- W66 E8362-20008 Channel R2 attenuator to REFERENCE 2 SOURCE OUT
- W67 E8362-20020 A25 test port 1 coupler to PORT 1 CPLR ARM
- W69 E8362-20022 PORT 1 RCVR A IN to A27 channel A mixer
- W81 E8362-20024 A36 step attenuator to PORT 1 SOURCE OUT
- W83 E8362-20012 PORT 1 CPLR THRU to A38 bias tee
- W65 E8362-20007 Channel R1 attenuator to REFERENCE 1 SOURCE OUT

Figure 8 Option 014 Cable Installation, Analyzers with Option UNL

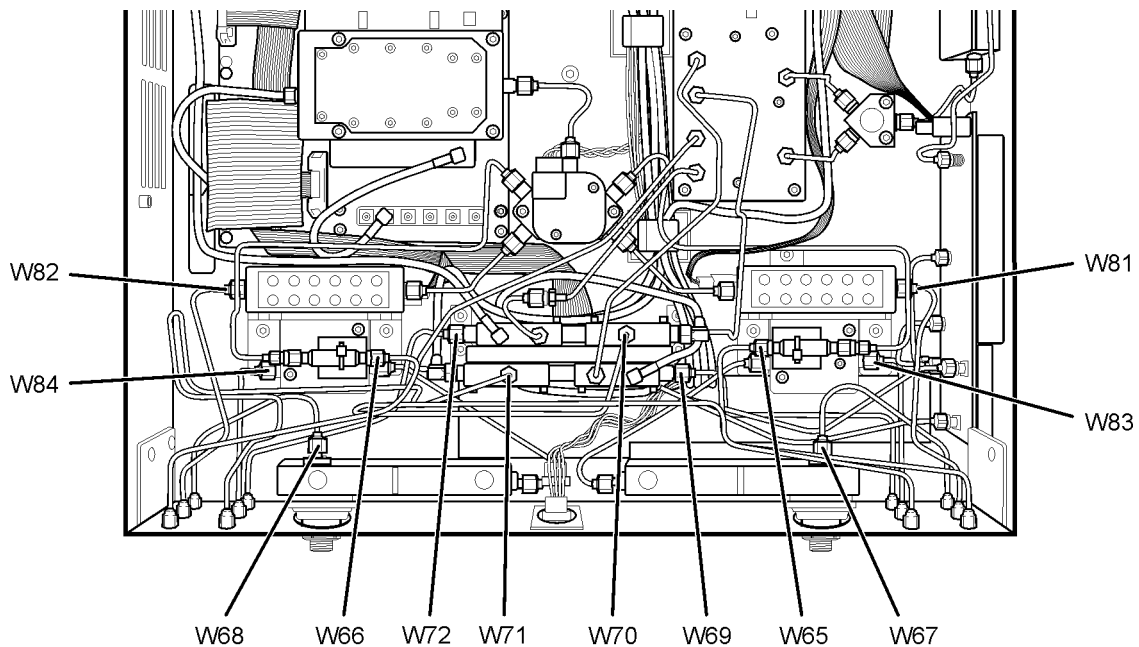

cbl_inst_unl

Step 6. Lower and Fasten the Receiver Deck

Refer to [Figure 9](#) for this procedure.

1. Pull the latch pin (item ②) toward the center of the analyzer to release the receiver deck.
2. Lift the receiver deck to partially lower it, then release the latch pin (item ②). Lower the receiver deck to its fully lowered position and ensure that the latch pin latches in the lowered position.
3. With a T-10 TORX driver, install the four screws (item ①) to secure the receiver deck.

Figure 9 Receiver Deck, Lowering

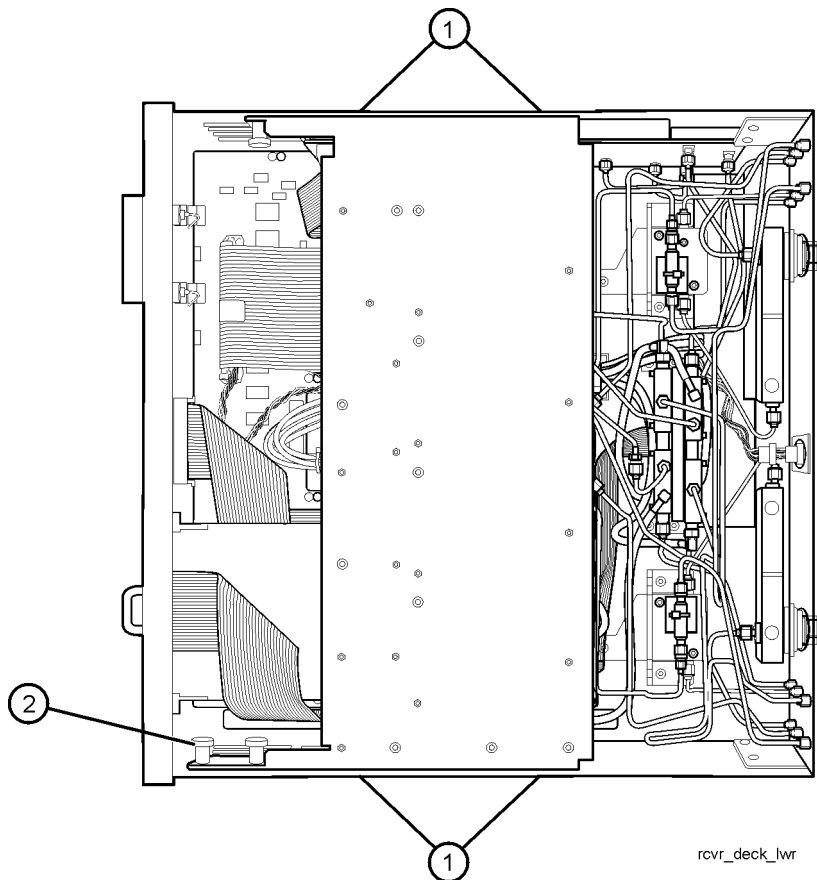

Step 7. Replace the Lower Front Panel Overlay

NOTE The new parts referenced in this procedure are listed in [Table 1 on page 4](#).

Refer to [Figure 10](#) for this procedure.

1. From the back side of the front panel, use a blunt object in one of the cutouts in the lower frame to push the overlay (item ①) and separate it from the front panel.
2. From the front side of the front panel, pull the overlay completely off and discard it.
3. Remove any adhesive remaining on the front panel.
4. Remove the protective backing from the new front panel overlay (item ①). Note that there are two overlays provided: one for Option 014 only and one for Option 014 in combination with Option UNL. Make sure you install the proper one for your analyzer:
 - The Port 1 and 2 SOURCE OUT labels for the Option 014 only overlay reads 40 VDC.
 - The Port 1 and 2 SOURCE OUT labels for the Option UNL/014 overlay reads 0 VDC.
5. Starting from either the left or right side, *loosely* place the overlay in the recess on the lower front panel, ensuring that it fits tightly against the recess edges.
6. Once the overlay is in place, press it firmly onto the frame to secure it.

Figure 10 Lower Front Panel Overlay Replacement

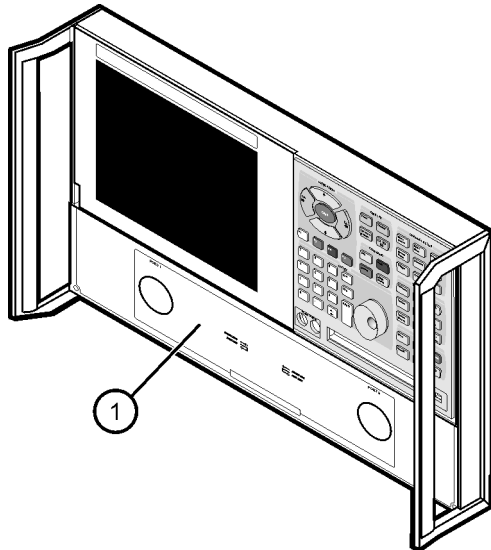

dt519a

Step 8. Reinstall the Front Panel Assembly and Install the Front Panel Jumpers

CAUTION Before installing the front panel assembly onto the analyzer, lift and support the front of the analyzer chassis.

Refer to [Figure 11](#) for this procedure.

1. Tighten all 12 of the front-panel feed-through connectors using a 5/16-in torque wrench set to 21-in lbs.
2. Reconnect the ribbon cable (item ①) to the A3 front panel interface board.
3. Slide the front panel over the test port connectors being careful to align the power switch and floppy disk drive to their corresponding front panel cutouts. Ensure that the ribbon cable ① is located below the fan to prevent it from being damaged by the fan blades.
4. With a T-10 TORX driver, install the eight screws (item ②) in the sides of the frame.
5. Install the six semirigid jumpers (item ③) on the front panel, and tighten to 10-in lbs.

Figure 11 Front Panel Assembly Reinstallation

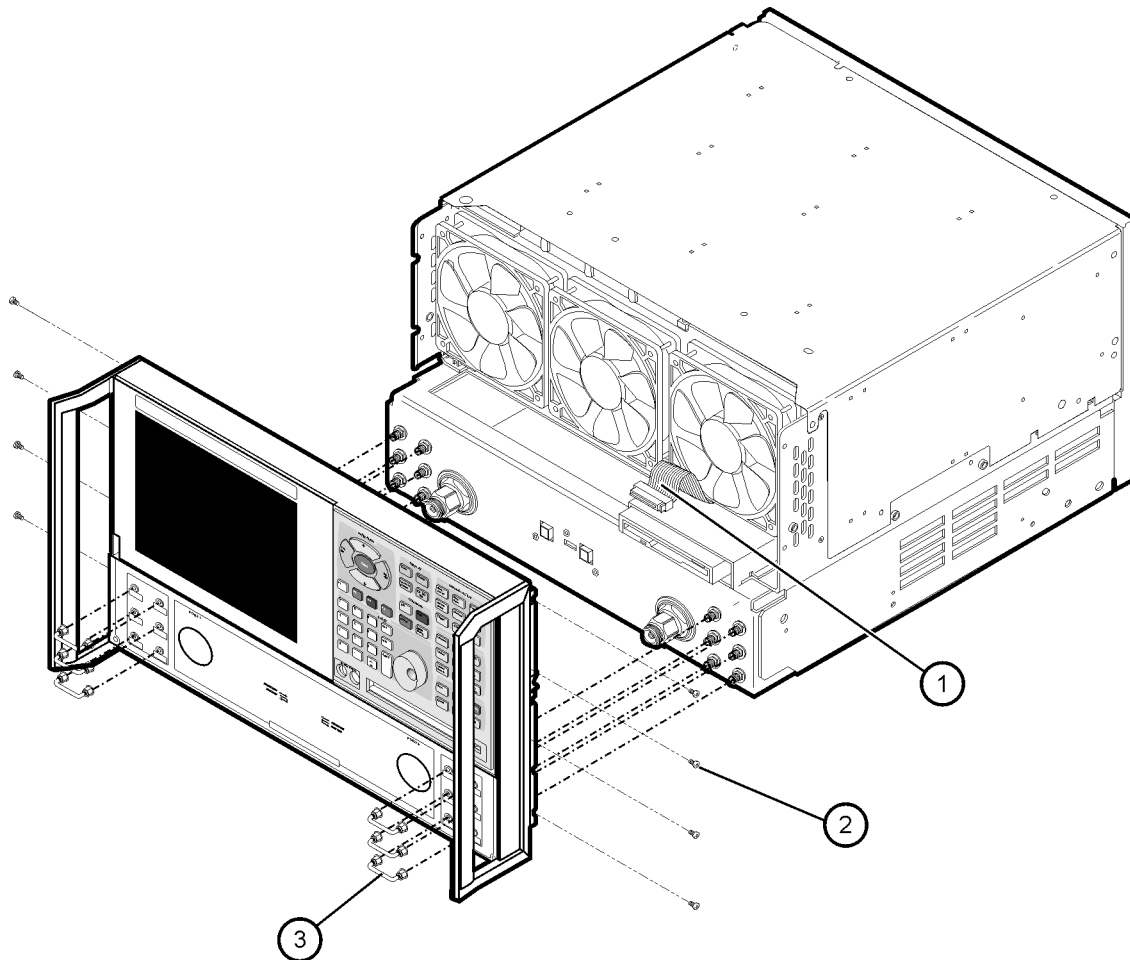

dt511a

Step 9. Reinstall the Outer Cover

CAUTION This procedure is best performed with the analyzer resting on its front handles in the vertical position. *Do not place the analyzer on its front panel without the handles.* This will damage the front panel assemblies.

Refer to [Figure 12](#) for this procedure.

1. Slide the cover over the analyzer frame.
2. With a T-20 TORX driver, install the four rear panel feet (item ①) by installing the center screws (item ②).
3. Slide the four bottom feet (item ③) into position on the cover.
4. With a T-20 TORX driver, install the strap handles (item ④) by installing the screws (item ⑤) on both ends of the handle.

Figure 12 Outer Cover Reinstallation

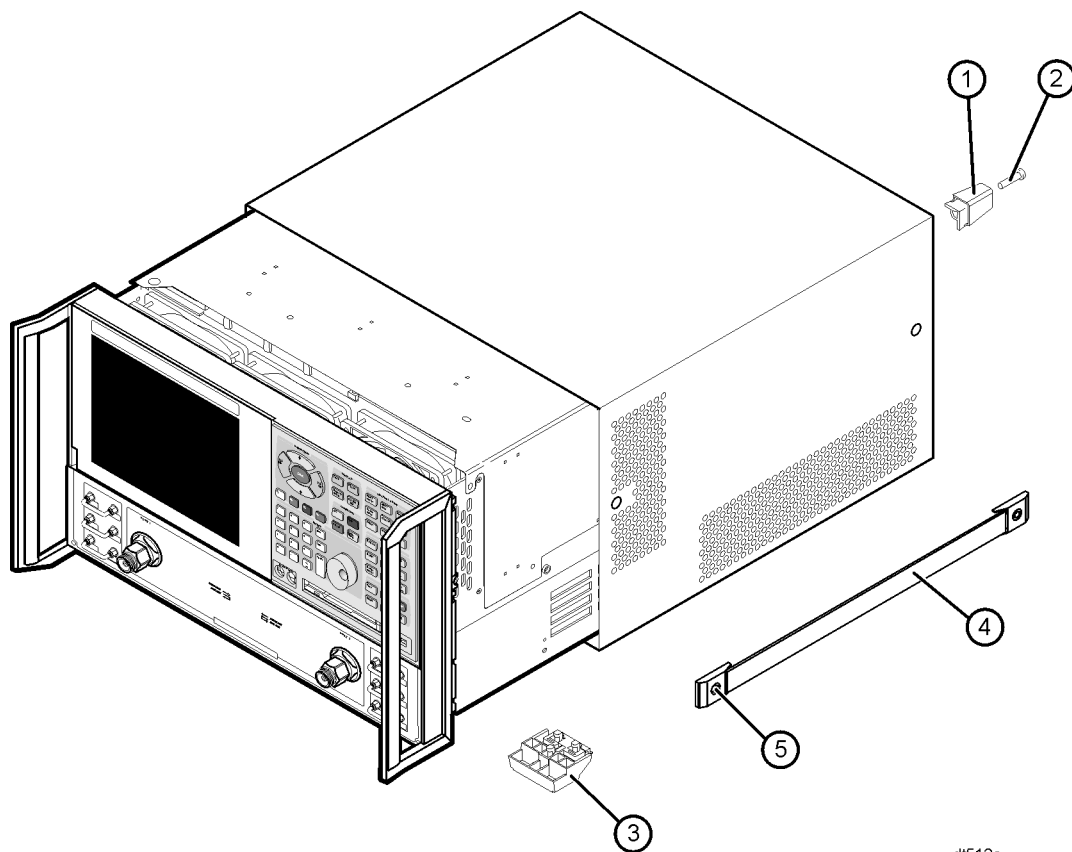

dt512a

Step 10. Enable Option 014

Procedure Requirements

- The analyzer must be powered up and operating to perform this procedure.
- The Network Analyzer program must be running.
- A mouse is recommended for this procedure but is not required.

Mouse Procedure

1. On the analyzer's **System** menu, point to **Service**, and then click **Option Enable**.
2. In the **Select Desired Option** list, click **014 - Configurable Test Set**.
3. Click **Install**.
4. Click **Yes** in answer to the displayed question in the **Restart Analyzer?** box.
5. When the installation is complete, click **Exit**.

Front Panel Keys Procedure

1. In the **COMMAND** block, press **Menu/Dialog**.
2. In the **NAVIGATION** block, press the Right Tab and Arrows to move over to the **System** menu and down to the **Service** selection. Press the Right Tab to display the extended menu and the Arrows to select **Option Enable**. Press **Click**.
3. Tab to the **Select Desired Option** list, and press Arrows to select **014 - Configurable Test Set**.
4. Tab to **Install**, and then press **Click**.
5. Click **Yes** in answer to the displayed question in the **Restart Analyzer?** box.
6. When the installation is complete, in the **COMMAND** block, press **OK** (or tab to **OK**, and then press **Click**).

Step 11. Verify that Option 014 Is Enabled

Procedure Requirements

- The analyzer must be powered up and operating to perform this procedure.
- The Network Analyzer program must be running.
- A mouse is recommended for this procedure but is not required.

Mouse Procedure

1. On the analyzer's **Help** menu, click **About Network Analyzer**.
2. Verify that "014" is listed after "Options:" in the display. Click **OK**.

NOTE If Option 014 has not been enabled, perform step 10 again. If the option is still not enabled, contact Agilent Technologies. Refer to ["Getting Assistance from Agilent" on page 2](#).

Front Panel Keys Procedure

1. In the **COMMAND** block, press **Menu/Dialog**.
2. In the **NAVIGATION** block, press the Right Tab and Arrows to move over to the **Help** menu, and down to the **About Network Analyzer** selection. Press **Click**.
3. Verify that "014" is listed after "Options:" in the display. In the **COMMAND** block, press **OK** (or tab to **OK**, and then press **Click**).

NOTE If Option 014 has not been enabled, perform step 10 again. If the option is still not enabled, contact Agilent Technologies. Refer to ["Getting Assistance from Agilent" on page 2](#).
